

# APECS 4500 CAN Controller



## Applications

The APECS 4500 CAN controller is designed for integration into commercial and construction vehicles, and industrial engine systems and compressors by original equipment manufacturers and industrial plants. It is also suitable for low speed (<25 kph [15.53 mph]) non-consumer off-highway vehicles. Typical applications include generator sets, compressors, construction machinery, and farm vehicles.

### CAN 2.0B SPECIFICATION

CAN functionality of the APECS 4500 CAN controller conforms to SAE J1939 protocol, the CAN bus standard adopted widely by engine and vehicle manufacturers for communication and diagnostics among engine components.

The 4500 CAN performs serial communication in accordance with CAN Specification 2.0B. By receiving data from engine components and transmitting commands, the controller can be used to command engine speed and communicate engine-operating parameters.

## Description

Woodward's APECS 4500 CAN controller provides maximum control and optimal engine performance. By adjusting the fuel control lever with a Woodward proportional actuator the 4500 CAN controls and limits engine speed. By adjusting to load, temperature, and other parameters, it optimizes engine performance and emissions.

### ENGINE CONTROL

The controller measures engine speed, compares it to the desired engine speed setpoint, and adjusts the current to the actuator to achieve the appropriate engine fueling command. The actuator is attached to the engine's control lever. In spark-ignited engines (i.e. gasoline, CNG or LP), the control lever is generally attached to the throttle. In compression-ignition (diesel) engines, the control lever may be attached to a fuel shutdown lever, a mechanical governor lever, or directly to the injector pump rack.

- CAN/J1939 bus interface
- Controls engine/ground speed and rate of acceleration
- Configurable for drive-by-wire operation, variable speed operation, and PTO operation
- Capable of isochronous load sharing and grid parallel operation
- Compatible with magnetic pickup, coil ignition, magneto ignition, and Hall Effect sensor
- Provides engine protection by monitoring engine coolant and oil pressure
- Easy to customize and reprogram

## Specifications

<b>Operating Temperature</b>	-40 °C to 85 °C (-40 °F to 185 °F)
<b>Power Input</b>	9-30 Vdc, reverse polarity protected
<b>Output to Actuator</b>	Pulse-width-modulated, 6A maximum
<b>Auxiliary Outputs</b>	200 mA maximum
<b>EMI Immunity (ISO 11452-1 &amp; ISO 11452-2)</b>	100 V/m, 200 to 1000 MHz
<b>Vibration</b>	6 Gs from 40 Hz to 2000 Hz
<b>Shock</b>	20 Gs at 45 Hz
<b>Calibration</b>	Requires interface adapter and software for calibration
<b>Enclosure</b>	Deutsch enclosure with two 12-way sealed connectors
<b>Mounting</b>	In engine compartment, but not on engine itself
<b>Weight</b>	Approx. 0.27 kg (0.6 lb)

## Dimensions

APECS 4500 CAN has two 12-pin Deutsch connectors labeled J1 and J2. Deutsch part numbers are DTM06-12SA (J1) and DTM06-12SB (J2). Woodward mating connector kit part number is SA-4490. For installation instructions please refer to technical manual 36752, which is available at [www.woodward.com/searchpublications.aspx](http://www.woodward.com/searchpublications.aspx).

Dimensions in brackets are in millimeters.

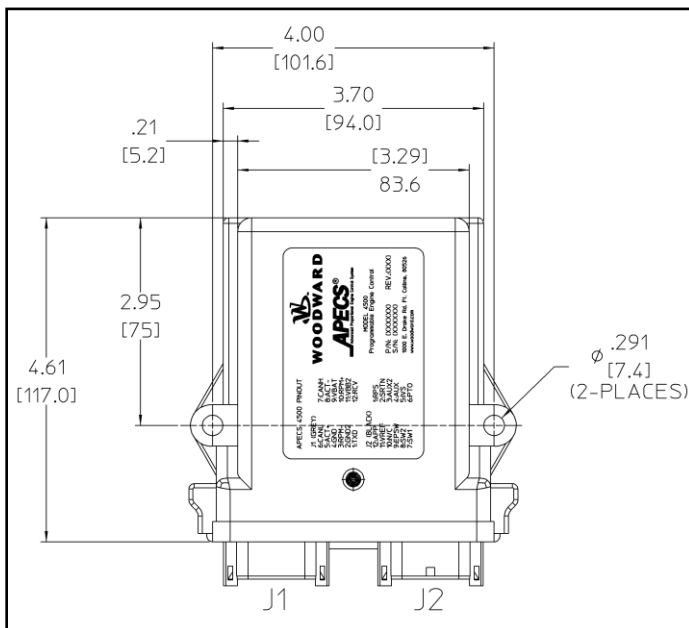

DRAWING NO. 5555-1217

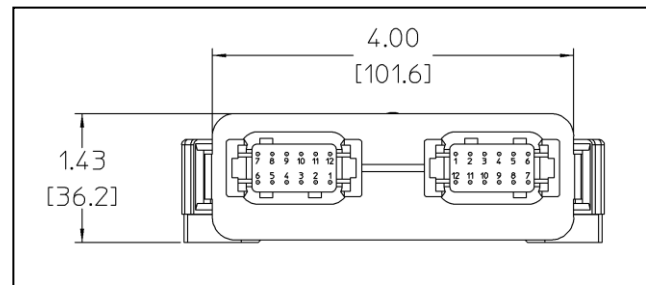

## Features

---

- *CAN/J1939 bus interface* can be used to command engine speed and communicate engine-operating parameters.
- *Control capabilities* include engine/ ground speed control, rate of acceleration control, drive-by-wire operation, variable speed operation, and power take-off operation.
- *Calibration* is simple using ACT, Woodward's proprietary software. The controller can be calibrated on any IBM-compatible PC, allowing for easy customization and re-programmability.
- *Universal speed input* permits use with magnetic pickups, coil-type spark ignition systems, magneto spark ignition systems, and Hall Effect sensors.
- *Internal diagnostics* monitor engine operation and display fault codes to indicate engine or system malfunction. Built-in engine protection capability can monitor engine coolant and oil pressure.
- *Sealed, waterproof connectors* assure reliability in harsh environments.

### Programmable Features

- *Analog speed setpoint input* is suitable for use with a potentiometer or an accelerator pedal position sensor (idle verification available).
- *Analog speed bias input* is available for isochronous load sharing in stationary power generation applications.
- *Actuator current protection* protects actuator from burning out.
- *Autocrank* permits remote operation of engines.
- *Auxiliary output* drives a lamp or relay.
- *Droop governing* allows non-isochronous speed governing.
- *Engine protection input* protects against adverse conditions such as loss of engine oil pressure or excessive coolant temperature.
- *Engine start calibration* expedites special startup operations such as warm-up speed, reduced governor gains, and missing speed signal.
- *Overspeed / underspeed protection*
- *PID gain adjustment* allows governor response to be adjusted by user.
- *PTO switch input* permits selection between analog speed setpoint input and switched speed setpoint inputs in mobile applications.
- *Switched speed setpoint inputs* allow multiple speed settings using switches. This feature can be configured together with the analog input (speed pot) for a variety of speed select options.



PO Box 1519, Fort Collins CO, USA 80522-1519  
1000 East Drake Road, Fort Collins CO 80525  
Tel.: +1 (970) 482-5811 ♦ Fax: +1 (970) 498-3058  
[www.woodward.com](http://www.woodward.com)

**Distributors & Service**

Woodward has an international network of distributors and service facilities. For your nearest representative, call the Fort Collins plant or see the Worldwide Directory on our website.

This document is distributed for informational purposes only. It is not to be construed as creating or becoming part of any Woodward contractual or warranty obligation unless expressly stated in a written sales contract.

© Woodward 2011, All Rights Reserved

For more information contact: