

**Solenoid Operated Shutdown Assembly  
for PGA and PGPL**

**Operation Manual**



### General Precautions

Read this entire manual and all other publications pertaining to the work to be performed before installing, operating, or servicing this equipment.

Practice all plant and safety instructions and precautions.

Failure to follow instructions can cause personal injury and/or property damage.



### Revisions

This publication may have been revised or updated since this copy was produced. To verify that you have the latest revision, check manual **26311**, *Revision Status & Distribution Restrictions of Woodward Technical Publications*, on the *publications page* of the Woodward website:

[www.woodward.com/publications](http://www.woodward.com/publications)

The latest version of most publications is available on the *publications page*. If your publication is not there, please contact your customer service representative to get the latest copy.



### Proper Use

Any unauthorized modifications to or use of this equipment outside its specified mechanical, electrical, or other operating limits may cause personal injury and/or property damage, including damage to the equipment. Any such unauthorized modifications: (i) constitute "misuse" and/or "negligence" within the meaning of the product warranty thereby excluding warranty coverage for any resulting damage, and (ii) invalidate product certifications or listings.



### Translated Publications

If the cover of this publication states "Translation of the Original Instructions" please note:

The original source of this publication may have been updated since this translation was made. Be sure to check manual **26311**, *Revision Status & Distribution Restrictions of Woodward Technical Publications*, to verify whether this translation is up to date. Out-of-date translations are marked with . Always compare with the original for technical specifications and for proper and safe installation and operation procedures.

## Warnings and Notices

### Important Definitions



This is the safety alert symbol. It is used to alert you to potential personal injury hazards. Obey all safety messages that follow this symbol to avoid possible injury or death.

- **DANGER**—Indicates a hazardous situation which, if not avoided, will result in death or serious injury.
- **WARNING**—Indicates a hazardous situation which, if not avoided, could result in death or serious injury.
- **CAUTION**—Indicates a hazardous situation which, if not avoided, could result in minor or moderate injury.
- **NOTICE**—Indicates a hazard that could result in property damage only (including damage to the control).
- **IMPORTANT**—Designates an operating tip or maintenance suggestion.

#### **WARNING**

**Overspeed /  
Overtemperature /  
Overpressure**

The engine, turbine, or other type of prime mover should be equipped with an overspeed shutdown device to protect against runaway or damage to the prime mover with possible personal injury, loss of life, or property damage.

The overspeed shutdown device must be totally independent of the prime mover control system. An overtemperature or overpressure shutdown device may also be needed for safety, as appropriate.

#### **WARNING**

**Personal Protective  
Equipment**

The products described in this publication may present risks that could lead to personal injury, loss of life, or property damage. Always wear the appropriate personal protective equipment (PPE) for the job at hand. Equipment that should be considered includes but is not limited to:

- Eye Protection
- Hearing Protection
- Hard Hat
- Gloves
- Safety Boots
- Respirator

Always read the proper Material Safety Data Sheet (MSDS) for any working fluid(s) and comply with recommended safety equipment.

#### **WARNING**

**Start-up**

Be prepared to make an emergency shutdown when starting the engine, turbine, or other type of prime mover, to protect against runaway or overspeed with possible personal injury, loss of life, or property damage.

#### **WARNING**

**Automotive  
Applications**

On- and off-highway Mobile Applications: Unless Woodward's control functions as the supervisory control, customer should install a system totally independent of the prime mover control system that monitors for supervisory control of engine (and takes appropriate action if supervisory control is lost) to protect against loss of engine control with possible personal injury, loss of life, or property damage.

**NOTICE****Battery Charging  
Device**

To prevent damage to a control system that uses an alternator or battery-charging device, make sure the charging device is turned off before disconnecting the battery from the system.

## Electrostatic Discharge Awareness

**NOTICE****Electrostatic  
Precautions**

Electronic controls contain static-sensitive parts. Observe the following precautions to prevent damage to these parts:

- Discharge body static before handling the control (with power to the control turned off, contact a grounded surface and maintain contact while handling the control).
- Avoid all plastic, vinyl, and Styrofoam (except antistatic versions) around printed circuit boards.
- Do not touch the components or conductors on a printed circuit board with your hands or with conductive devices.

To prevent damage to electronic components caused by improper handling, read and observe the precautions in Woodward manual **82715**, *Guide for Handling and Protection of Electronic Controls, Printed Circuit Boards, and Modules*.

Follow these precautions when working with or near the control.

1. Avoid the build-up of static electricity on your body by not wearing clothing made of synthetic materials. Wear cotton or cotton-blend materials as much as possible because these do not store static electric charges as much as synthetics.
2. Do not remove the printed circuit board (PCB) from the control cabinet unless absolutely necessary. If you must remove the PCB from the control cabinet, follow these precautions:
  - Do not touch any part of the PCB except the edges.
  - Do not touch the electrical conductors, the connectors, or the components with conductive devices or with your hands.
  - When replacing a PCB, keep the new PCB in the plastic antistatic protective bag it comes in until you are ready to install it. Immediately after removing the old PCB from the control cabinet, place it in the antistatic protective bag.

# Solenoid Operated Shutdown Assembly for PGA and PGPL

## General Description and Operation

This manual describes the solenoid operated shutdown assembly, including operation, adjustment, and replaceable parts.



**WARNING**

If the governor, for any reason, loses its ability to control the engine or turbine, the solenoid shutdown protection is also lost.

The solenoid operated shutdown assembly (Figure 1) can be incorporated in almost all PG governors having speed setting arrangements which use hydraulically operated speed setting servo assemblies (such as bellows direct—or reverse—speed setting, current controlled speed setting, etc). The solenoid is actuated by switches in the protective circuit being monitored. When actuated, the shutdown solenoid initiates a sequence of actions within the governor which results in the governor being moved to the shutdown or off position.

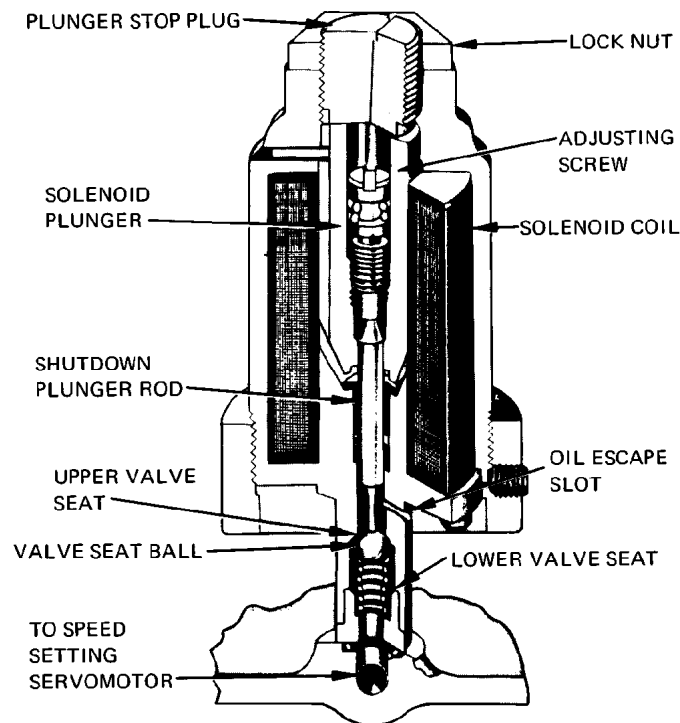

Figure 1. Cutaway of Solenoid Operated Shutdown

This assembly can be adjusted to effect governor shutdown either when energized or when de-energized. The assembly of the components is the same in either case.



**WARNING**

The shutdown solenoid must not be used as an overspeed protective device. Overspeed protection must come from a unit completely separate from the PG governor.

The shutdown solenoid can be used for normal shutdown and/or as a backup to the safety shutdown system. The engine, turbine, or other type of prime mover should be equipped with safety systems entirely separate from the governor. However, the safety system may be interfaced with the shutdown solenoid to cause the governor or actuator to go to minimum during safety systems shutdowns. As with all safety shutdowns, proper operation should be confirmed periodically. See the prime mover manufacturer's instructions.

Solenoid coils are available to accommodate most standard dc voltages. If operation on 110 Vac or 220 Vac is required, rectifiers are added to rectify the ac to dc.

## Operation

As shown in the schematic (Figure 2), the shutdown device consists essentially of a check valve and a solenoid. The check valve is inserted in the hydraulic circuit between the speed setting servo assembly and the speed setting pilot valve plunger and bushing. When the ball in the check valve is unseated, oil above the speed setting servo piston escapes to sump. This allows the servo piston spring to push the speed setting servo piston up. When the servo piston moves up sufficiently, the piston rod lifts the shutdown nuts and shutdown rod which is connected to the governor pilot valve plunger. Therefore, lifting the shutdown rod lifts the pilot valve plunger. With the pilot valve plunger above center, oil is released through the control port to sump, and the governor power piston moves the fuel linkage in the decrease direction.

As seen in Figure 1, the check ball seats against two valve seats. In units adjusted to shut down when the solenoid coil is energized, the spring holds the check ball against the upper seat during normal operation. When the coil is energized, the plunger rod moves down, unseating the check ball. In units adjusted to shut down when the solenoid is de-energized, the plunger rod is adjusted to hold the check ball on the lower seat during normal operation (when the solenoid is energized). When the solenoid coil is de-energized, the spring pushes the check ball upward, unseating it.

## Calibration Procedure

### For Energize to Shutdown (see Figure 1)

With the governor controlling, remove the lock nut and the plunger stop plug. Energize the solenoid. Turn the adjusting screw down (clockwise) until oil just starts to seep from the slot in the shutdown valve body. Turn the adjusting screw down 1-1/4 turns further. With the solenoid still energized, insert the plunger stop plug and screw the plug down until it just touches the plunger. Back off the plunger stop plug 2 turns, and lock it in place with the lock nut. This procedure will adjust the ball check valve to dump oil from the upper valve seat.

### For De-energize to Shutdown

Remove the lock nut and the plunger stop plug. Energize the solenoid. Turn the adjusting screw down until the ball just contacts the lower seat. (You will see the shutdown release oil from the valve body when the ball first leaves the upper seat. It will continue to dump oil until the ball contacts the lower seat. The oil will then stop flowing and the governor will resume control.) Turn the adjusting screw down another 1-1/4 turns beyond the point where the oil just stops flowing (this will force the plunger up). With the solenoid still energized, insert the plunger stop plug and screw the plug down until it just touches the solenoid plunger. Back off the plunger stop plug 2 turns and lock it in place with the lock nut.

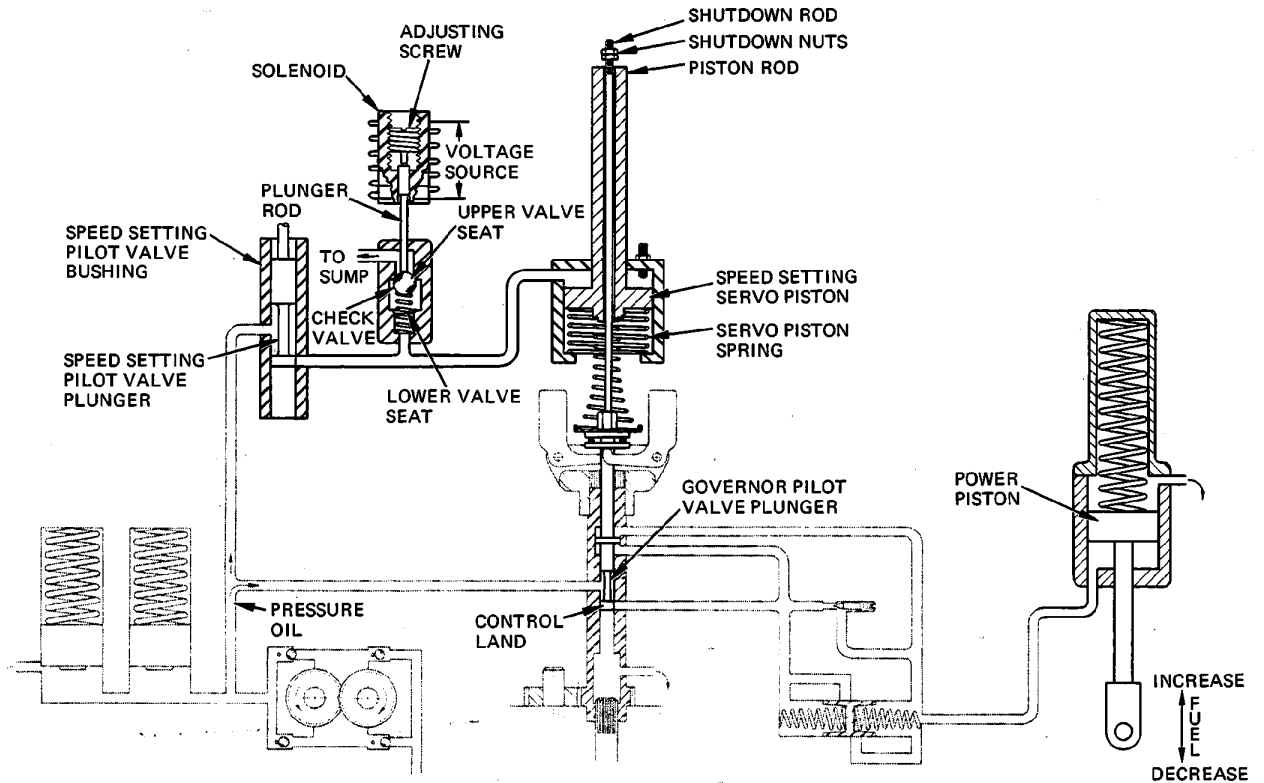

Figure 2. Schematic Diagram of Basic PG and Solenoid Shutdown

## Diode Kit

One piece diode kits are available for replacement for the old-style micarta mounting block systems. Electrical values of the improved diode kit are identical. Follow the instructions below to install the new diode kit:

1. Remove the existing diodes, wires, micarta plate, and related hardware. Note which connector terminals are used. (Most units have the yellow wire connected to the A terminal and the black wire connected to the B terminal. However, this can vary: replace to the same terminals used before, being careful to maintain polarity.)
2. Install the new round diode kit in place of the old mounting block. Secure with a mounting screw removed from the old assembly.
3. Cut the yellow and black wires to length. Install the protective tubing and solder to the proper terminals in the connector as noted in step 1.
4. Cut the white and black wires to length. Install the protective tubing and solder to the terminals in the bottom of the solenoid. Polarity is not important.
5. Test a repaired shutdown device on a test stand, if possible. If testing the repaired shutdown device on an engine, be prepared to shut down the engine in some other manner should the repaired device not function properly.



**WARNING** The shutdown device must not be used as an emergency shutdown. The emergency shutdown device must be completely separate and not connected to the governor if it is to provide adequate protection to the engine and to the engine operator.



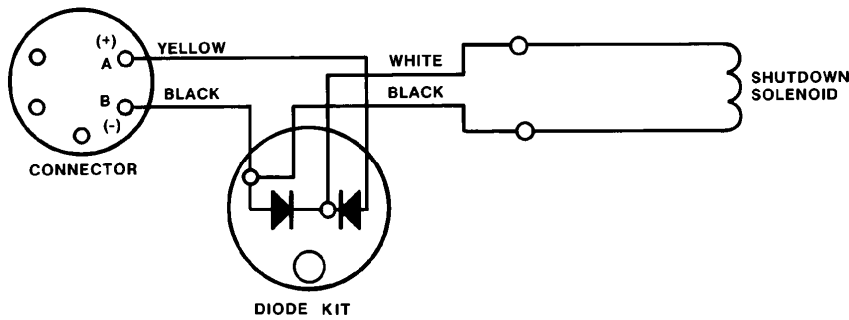

Figure 3. Wiring Schematic

## Replacement Parts

When ordering replacement parts, it is essential to include the following information:

- Governor serial number and part number shown on nameplate
- Manual number (this is manual 36650)
- Parts reference number in parts list and description of part or part name

The illustrated parts breakdown (Figure 4) shows all the replaceable parts for solenoid shutdown. The numbers assigned are used as reference numbers and are not specific Woodward part numbers—Woodward will determine the exact part number for your particular unit.

## Parts List

Ref. No.	Part Name.....Quantity	Ref. No.	Part Name.....Quantity
36650-1	Solenoid locknut.....1	36650-26	Plunger stop plug.....1
36650-2	Plunger stop plug.....1	36650-27	Headed pin.....1
36650-3	Solenoid plunger lock pin.....1	36650-28	Receptacle.....1
36650-4	Solenoid case.....1	36650-29	Connector (optional).....1
36650-5	Load spring.....1	36650-30	Coupling (optional).....1
36650-6	Insulating paper.....1	36650-31	Spacer.....4
36650-7	Solenoid coil.....1	36650-32	Dial plate.....1
36650-8	Soldering shield washer.....2	36650-33	Screw, 6-32 x 3/8".....4
36650-9	O-ring.....2	36650-34	Gasket.....1
36650-10	Adjusting screw.....1	36650-35	Screw, 4-40 x 1/4".....4
36650-11	Solenoid plunger assembly.....1	36650-36	O-ring.....1
36650-12	Solenoid plunger washer.....1	36650-37	Diode Kit.....1
36650-13	Solenoid plunger rod.....1	36650-37A	Screw.....1
36650-14	Solenoid plunger bushing.....2	36650-37B	Lockwasher.....1
36650-15	Shutdown valve body.....1	36650-37C	Washer, 0.149 x 0.375 OD.....1
36650-16	Varnished tubing.....2	36650-37D	Rd. hd. screw, 6-32.....1
36650-17	Plunger guide locating pin.....1	36650-37E	Shakeproof washer.....1
36650-18	Steel ball, 1/4" dia.....1	36650-37F	Wire clip.....1
36650-19	Unloading spring.....1	36650-37G	Plastic tubing.....AR
36650-20	Valve seat.....1	36650-37H	Micarta mounting block.....1
36650-21	Plunger cap.....1	36650-37I	Wire bundle strap.....1
36650-22	Roll pin.....1	36650-37J	Soldering lug.....1
36650-23	Spring.....1	36650-37K	Diode.....2
36650-24	Bearing plug.....1	36650-37L	Paper insulator.....1
36650-25	Manual shutdown plunger.....1	36650-37M	Rectifier cover.....1



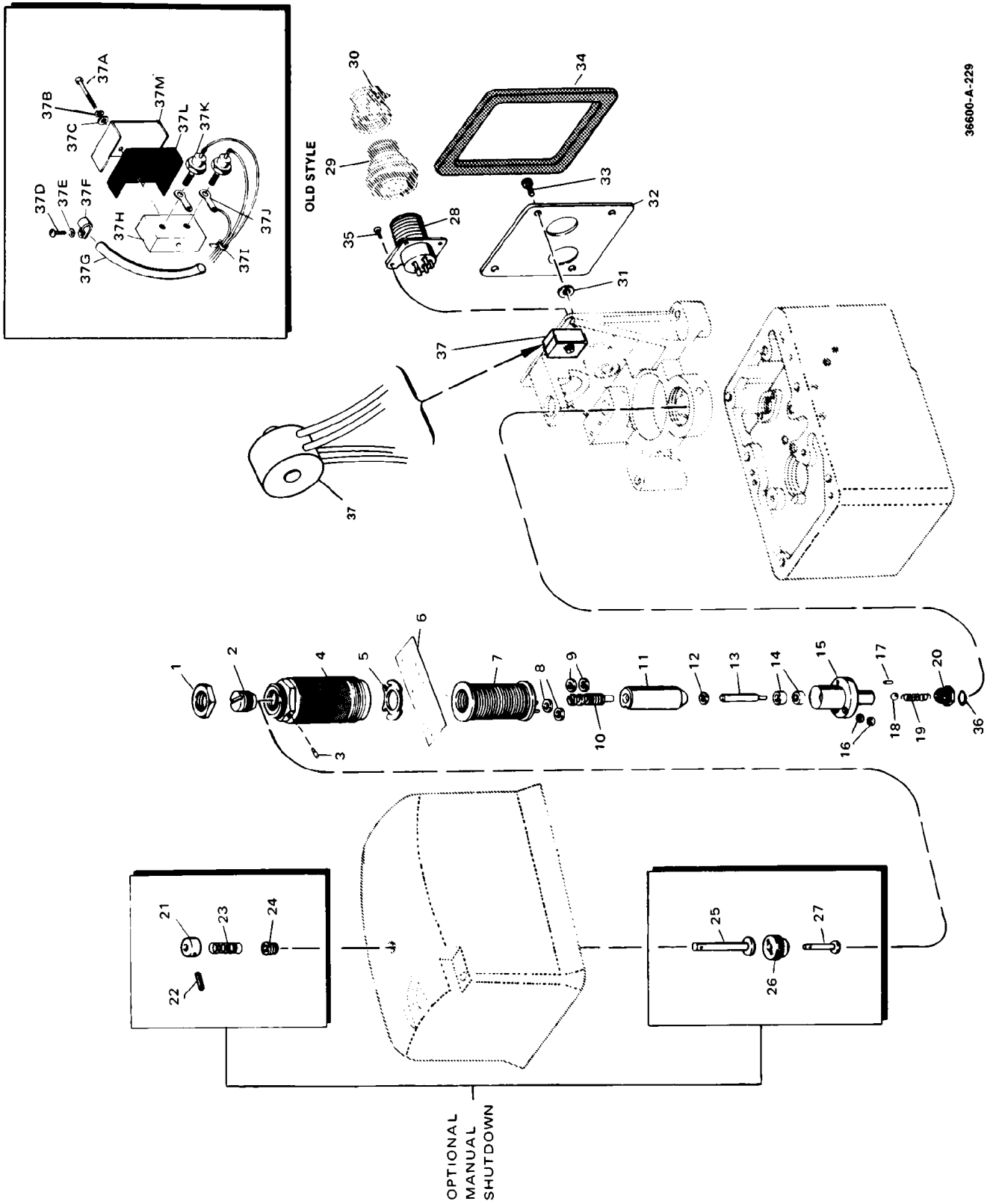

Figure 4. Solenoid Shutdown Exploded View

We appreciate your comments about the content of our publications.

Send comments to: [icinfo@woodward.com](mailto:icinfo@woodward.com)

Please reference publication **36650H**.



PO Box 1519, Fort Collins CO 80522-1519, USA  
1000 East Drake Road, Fort Collins CO 80525, USA  
Phone +1 (970) 482-5811 • Fax +1 (970) 498-3058

Email and Website—[www.woodward.com](http://www.woodward.com)

**Woodward has company-owned plants, subsidiaries, and branches,  
as well as authorized distributors and other authorized service and sales facilities throughout the world.**

**Complete address / phone / fax / email information for all locations is available on our website.**